



惠柏國際有限公司專為國內超音波業, 引進國外品質優秀,性能可靠之各式震盪器技術,最近為提供更優惠之價格,所以不惜重金引進日本技術,並且在台灣及大陸自設工廠加工,製造,組裝,供貨,希望因此讓舊雨新知能在成本上,及品質上更能與國際廠家競爭。

"惠柏"另也提供一系列之壓電陶瓷相關部品,產品廣泛可應用於:

- 超音波加濕,霧化
- 焊接
- 拋光
- 萃取
- 清洗,除毛邊,去渣
- 鑽孔
- 乳化
- 量測

歡迎洽詢選購使用



惠柏國際有限公司 WHIRL BEST INTERNATIONAL CO., LTD.

公司地址: 干32659台灣桃園市楊梅區永平路15號

Tel: +886-3-496-2308 Fax: +886-3-464-3587

E-mail: whbest.a168@msa.hinet.net Website: <http://www.whbest168.com>

Whirl Best International Co., Ltd. specializes in Ultrasound Business. Whirl Best spared no expense to introduce and adopt technologies from Japan to provide our customers with high-quality products. Moreover, to offer products at reasonable prices, we process, manufacture, assemble, and supply our products through our self-owned factories in Taiwan and Mainland China. Whirl Best aims to help our customers have the ability to compete with companies worldwide via great prices and qualities.



Whirl Best also provides a series of piezoelectric ceramic parts, which can be widely applied to ultrasonic humidification, ultrasonic atomization, welding, polishing, extraction, cleaning, deburring, drilling, emulsification, and measurement.



惠柏國際有限公司 WHIRL BEST INTERNATIONAL CO., LTD.
No.15, Yongping Rd., Yangmei Dist, Taoyuan City 32659, Taiwan (R.O.C.)
Tel: +886-3-496-2308 Fax:+886-3-464-3587
E-mail: whbest.a168@msa.hinet.net Website: <http://www.whbest168.com>

編號	WB1560-60HB
Model	(P8黃片)
共振頻率(kHz)	15±0.5
Resonant Frequency	
共振阻抗(Ω)	≤ 10
Resonant Impedance	
靜態電容	10,500PF±10%
Static Capacitance	
最大功率(W)	1500
Maximum Input Power	
前端外徑(mm)	$\phi 60$
Outside Diameter (Front End)	
壓電環外徑(mm)	$\phi 60$
Outside Diameter (Ceramic Ring)	
接觸面固定螺栓	M20*P1.5*25L
Fixing Bolt	
總高(mm)	165.5
Height	
重量(g)	2000
Weight	
最高使用液溫($^{\circ}\text{C}$)	80
Max. Temp. of Liquid	
包裝(pcs/ctn)	4
Packing	
外觀	如右圖
Appearance	As shown on the right



15K
1500W

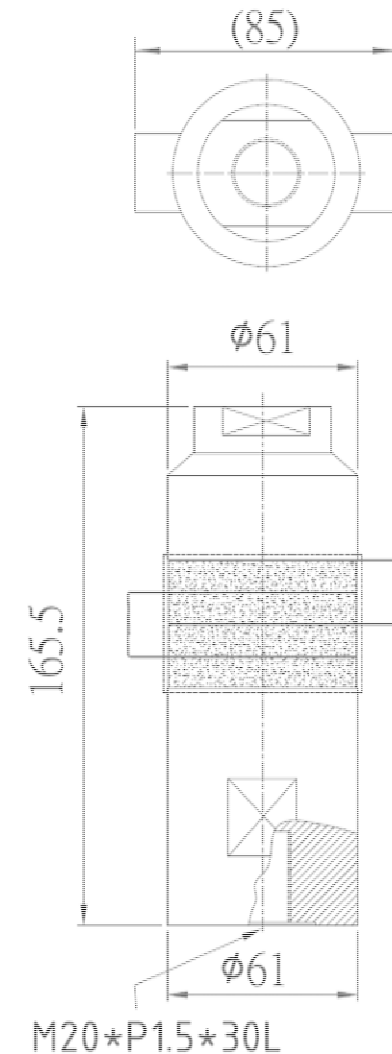

- 15K 1500W塑鐸機、口罩黏著機、聚能機使用
Suitable for plastic welding machine, mask sealing machine, ultrasonic processor, etc.

編號	WB2050-50HB
Model	(P8黃片)
共振頻率(kHz)	20±1.0
Resonant Frequency	
共振阻抗(Ω)	≤ 10
Resonant Impedance	
靜態電容	11,000PF±10%
Static Capacitance	
最大功率(W)	800
Maximum Input Power	
前端外徑(mm)	$\phi 50$
Outside Diameter (Front End)	
壓電環外徑(mm)	$\phi 50$
Outside Diameter (Ceramic Ring)	
接觸面固定螺栓	M20*P1.0*25L
Fixing Bolt	
總高(mm)	122.5
Height	
重量(g)	1800
Weight	
最高使用液溫($^{\circ}\text{C}$)	60
Max. Temp. of Liquid	
包裝(pcs/ctn)	4
Packing	
外觀	如右圖
Appearance	As shown on the right



20K
800W

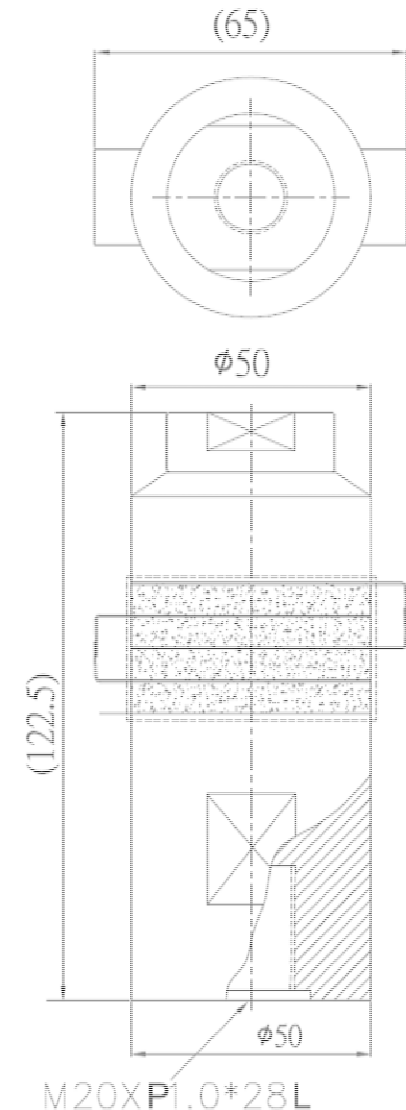

- 20K 800W 塑鐸機、口罩黏著機、聚能機使用
Suitable for plastic welding machine, mask sealing machine, ultrasonic processor, etc.

編號	WB2145-68LB
Model	(P8黃片)
共振頻率(kHz)	20.5±0.5
Resonant Frequency	
共振阻抗(Ω)	≤ 25
Resonant Impedance	
靜態電容	5500PF±10%
Static Capacitance	
最大功率(W)	85
Maximum Input Power	
前端外徑(mm)	$\phi 68$
Outside Diameter (Front End)	
壓電環外徑(mm)	$\phi 45$
Outside Diameter (Ceramic Ring)	
接觸面固定螺栓	M10*P1.0*10L
Fixing Bolt	
總高(mm)	94
Height	
重量(g)	934
Weight	
最高使用液溫($^{\circ}\text{C}$)	80
Max. Temp. of Liquid	
包裝(pcs/ctn)	15
Packing	
外觀	如右圖
Appearance	As shown on the right

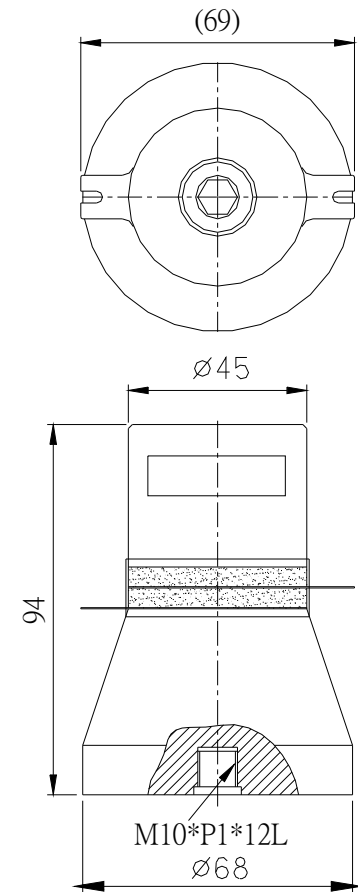

20.5K 85W

- 20K 100W低頻大功率清洗高爆發
- ✓ Low frequency; high ultrasonic power and high cleaning capability
- 對特別髒污的洗淨方案
- ✓ Suitable for degreasing
- 大底面積清洗出力非常均勻
- ✓ Bigger base - even output of power

編號	WB2335-45HB
Model	(P4黑片)
共振頻率(kHz)	23±0.5
Resonant Frequency	
共振阻抗(Ω)	≤ 25
Resonant Impedance	
靜態電容	8000PF±10%
Static Capacitance	
最大功率(W)	100
Maximum Input Power	
前端外徑(mm)	$\phi 45$
Outside Diameter (Front End)	
壓電環外徑(mm)	$\phi 35$
Outside Diameter (Ceramic Ring)	
接觸面固定螺栓	None
Fixing Bolt	
總高(mm)	91.5
Height	
重量(g)	500
Weight	
最高使用液溫($^{\circ}\text{C}$)	80
Max. Temp. of Liquid	
包裝(pcs/ctn)	30
Packing	
外觀	如右圖
Appearance	As shown on the right

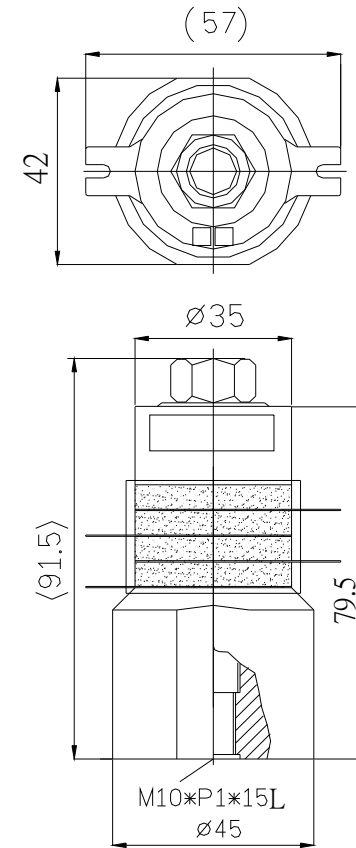

23K 100W

- 23K 100W低頻大功率清洗高爆發力
Low frequency; high ultrasonic power and high cleaning capability
- 對特別髒洗淨方案
Suitable for degreasing
- 需要高功率密度的設計案 相同面積下需要更高功率的場合
Suitable for conditions which require higher power under same limited area

編號	WB2538-63LB
Model	(P8黃片)
共振頻率(kHz)	25±0.5
Resonant Frequency	
共振阻抗(Ω)	≤25
Resonant Impedance	
靜態電容	3800PF±10%
Static Capacitance	
最大功率(W)	55
Maximum Input Power	
前端外徑(mm)	φ63
Outside Diameter (Front End)	
壓電環外徑(mm)	φ38
Outside Diameter (Ceramic Ring)	
接觸面固定螺栓	M10*P1.0*10L
Fixing Bolt	
總高(mm)	76
Height	
重量(g)	542
Weight	
最高使用液溫(°C)	80
Max. Temp. of Liquid	
包裝(pcs/ctn)	15
Packing	
外觀	如右圖
Appearance	As shown on the right

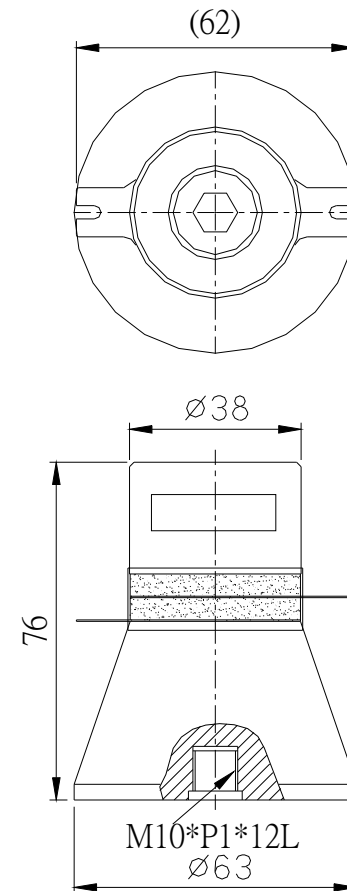

25K
55W

- **25K低頻清洗爆發力更強,大底面,出力均勻**
Low frequency; high ultrasonic output power and high cleaning capability; big base and even output of power
- **煤油清洗最佳方案**
Suitable option for kerosene cleaning
- **可做25K/52雙頻切換**
Can be used as two frequencies - 25K and 52K

編號	WB2835-45HB
Model	(P4黑片)
共振頻率(kHz)	28±0.5
Resonant Frequency	
共振阻抗(Ω)	≤25
Resonant Impedance	
靜態電容	4000PF±10%
Static Capacitance	
最大功率(W)	50
Maximum Input Power	
前端外徑(mm)	φ45
Outside Diameter (Front End)	
壓電環外徑(mm)	φ35
Outside Diameter (Ceramic Ring)	
接觸面固定螺栓	M10*P1.0*10L
Fixing Bolt	
總高(mm)	79
Height	
重量(g)	410
Weight	
最高使用液溫(°C)	80
Max. Temp. of Liquid	
包裝(pcs/ctn)	30
Packing	
外觀	如右圖
Appearance	As shown on the right



28K
50W

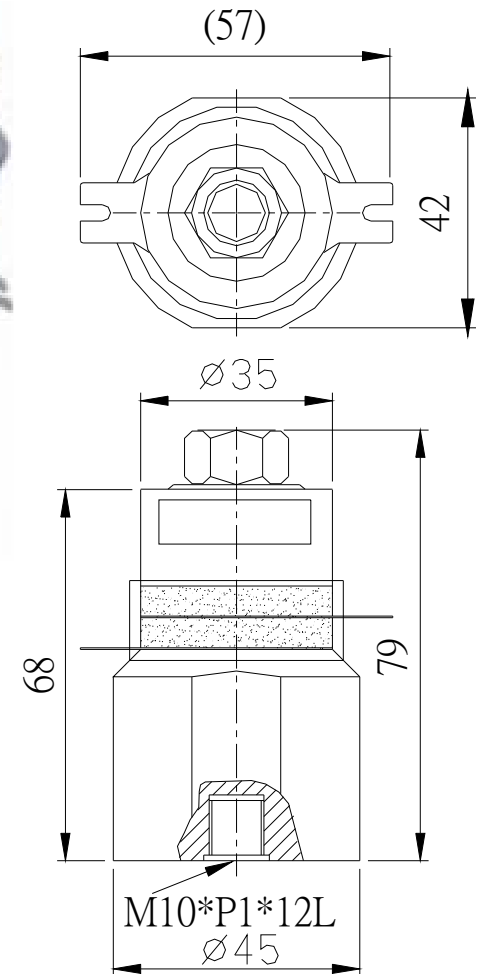

- 採用厚度較厚的高性能轉換壓電陶瓷片→出力大、轉換效率高、發熱少
Thicker piezoelectric ceramic ring adopted - great power and high efficiency
- 可做28K/50K雙頻切換
Can be used as two frequencies - 28K and 50K 8

編號	WB4035-45LB
Model	(P4黑片)
共振頻率(kHz)	40±0.5
Resonant Frequency	
共振阻抗(Ω)	≤25
Resonant Impedance	
靜態電容	4000PF±10%
Static Capacitance	
最大功率(W)	50
Maximum Input Power	
前端外徑(mm)	φ45
Outside Diameter (Front End)	
壓電環外徑(mm)	φ35
Outside Diameter (Ceramic Ring)	
接觸面固定螺栓	M10*P1.0*10L
Fixing Bolt	
總高(mm)	54
Height	
重量(g)	244
Weight	
最高使用液溫(°C)	80
Max. Temp. of Liquid	
包裝(pcs/ctn)	60
Packing	
外觀	如右圖
Appearance	As shown on the right

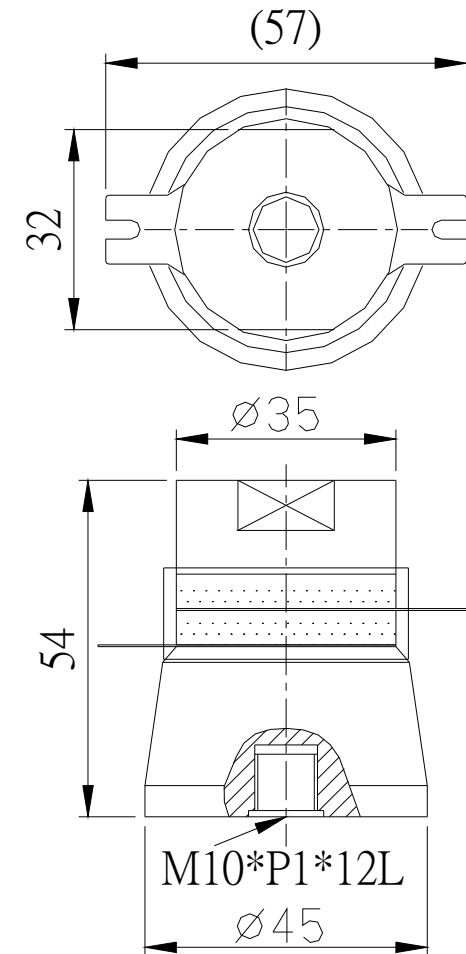

40K
50W

- 採用厚度較厚的高性能轉換壓電陶瓷片→出力大、轉換效率高、發熱少
Thicker piezoelectric ceramic ring adopted – great power and high efficiency
- 可做40K/68K雙頻切換
Can be used as two frequencies - 40K and 68K

編號	WB4035-45LA
Model	(P4黑片)
共振頻率(kHz)	40±0.5
Resonant Frequency	
共振阻抗(Ω)	≤ 25
Resonant Impedance	
靜態電容	4000PF±10%
Static Capacitance	
最大功率(W)	50
Maximum Input Power	
前端外徑(mm)	$\phi 45$
Outside Diameter (Front End)	
壓電環外徑(mm)	$\phi 35$
Outside Diameter (Ceramic Ring)	
接觸面固定螺栓	None (無孔)
Fixing Bolt	
總高(mm)	54
Height	
重量(g)	244
Weight	
最高使用液溫($^{\circ}\text{C}$)	80
Max. Temp. of Liquid	
包裝(pcs/ctn)	60
Packing	
外觀	如右圖
Appearance	As shown on the right

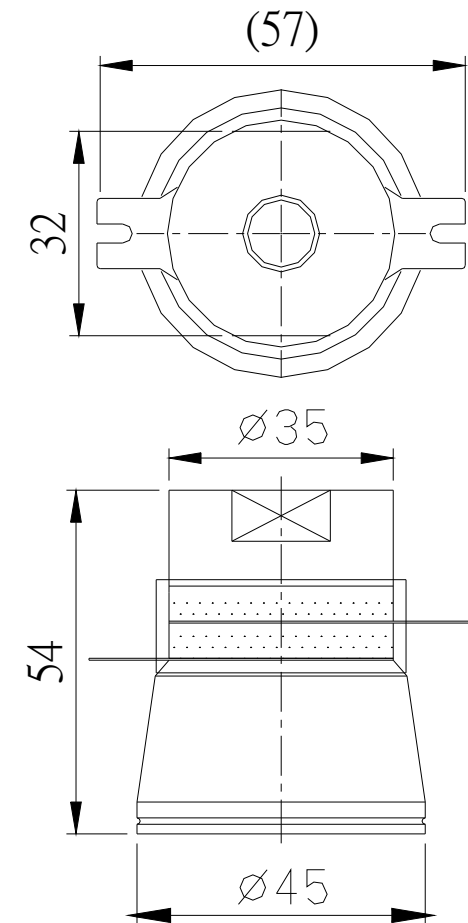
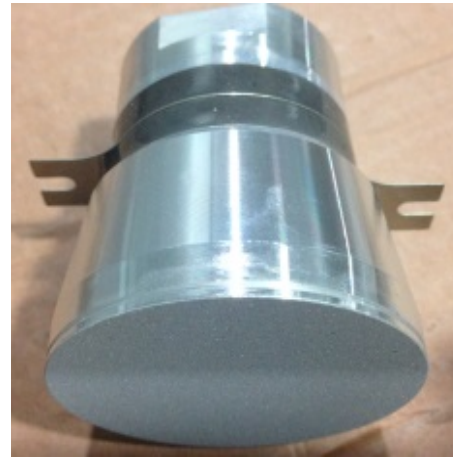

40K
50W
無孔

- 採用厚度較厚的高性能轉換壓電陶瓷片→出力大、效率高、發熱少
Thicker piezoelectric ceramic ring – great power and high efficiency
- 針對薄板無釘的設計案
Designed for projects which require plate-type transducers without studs

編號	WB4038-40HB
Model	(P8黃片)
共振頻率(kHz)	40±2
Resonant Frequency	
共振阻抗(Ω)	≤25
Resonant Impedance	
靜態電容	3300PF±10%
Static Capacitance	
最大功率(W)	65
Maximum Input Power	
前端外徑(mm)	φ40
Outside Diameter (Front End)	
壓電環外徑(mm)	φ38
Outside Diameter (Ceramic Ring)	
接觸面固定螺栓	M10*P1.0*10L
Fixing Bolt	
總高(mm)	55
Height	
重量(g)	283
Weight	
最高使用液溫(°C)	80
Max. Temp. of Liquid	
包裝(pcs/ctn)	30
Packing	
外觀	如右圖
Appearance	As shown on the right



40K
65W

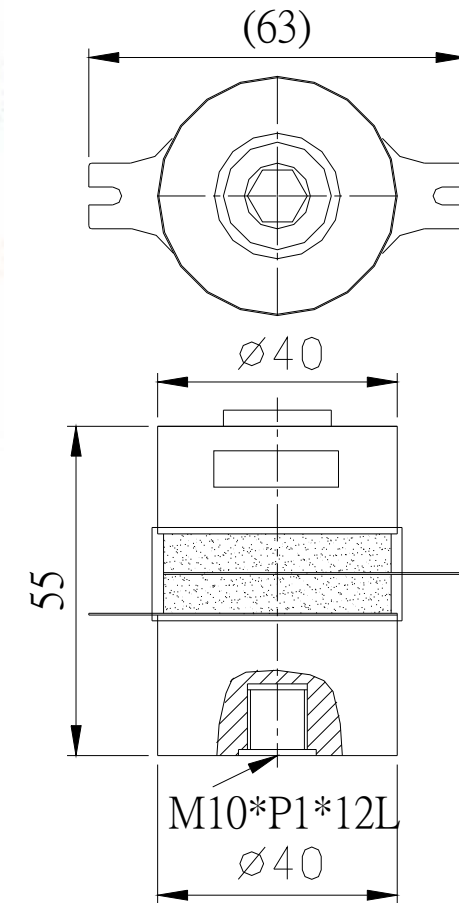

- 最佳的音爆清洗效果,高功率40K的動態音爆, 瓦特數可以高一點的40K
Great cavitation cleaning effect; high output power
- 可做三頻機使用40K/80K/133K切換
Can be used as three frequencies - 40K, 80K, and 133K

編號	WB6838-50HB
Model	(P8黃片)
共振頻率(kHz)	68±2
Resonant Frequency	
共振阻抗(Ω)	≤25
Resonant Impedance	
靜態電容	3800PF±10%
Static Capacitance	
最大功率(W)	60
Maximum Input Power	
前端外徑(mm)	φ50
Outside Diameter (Front End)	
壓電環外徑(mm)	φ38
Outside Diameter (Ceramic Ring)	
接觸面固定螺栓	M10*P1.0*10L
Fixing Bolt	
總高(mm)	73
Height	
重量(g)	457
Weight	
最高使用液溫(°C)	80
Max. Temp. of Liquid	
包裝(pcs/ctn)	20
Packing	
外觀	如右圖
Appearance	As shown on the right



68K 60W

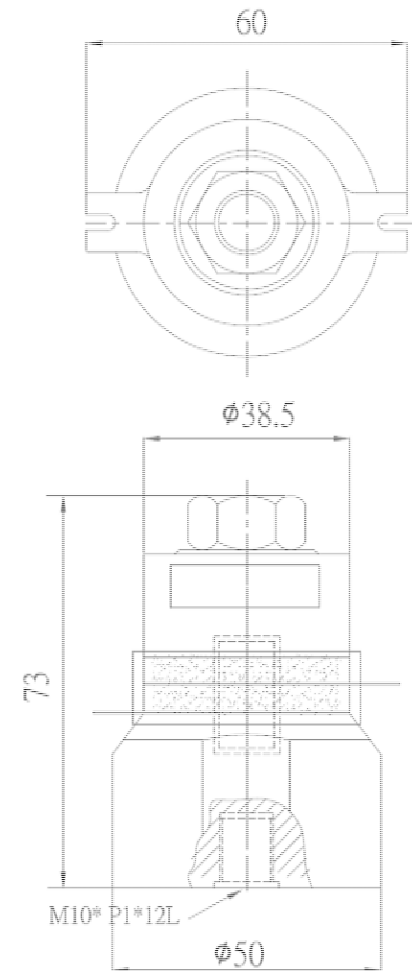

- 最佳的噴流清洗效果,高頻68K的動態細微噴流,半導體,面板業使用
Strong ultrasonic pressure wave; suitable for semiconductor industry and panel industry)
- 可做雙頻機使用30K/68K切換
Can be used as frequencies - 30K and 68K

編號	WB8038-40HB
Model	(P8黃片)
共振頻率(kHz)	80±2
Resonant Frequency	
共振阻抗(Ω)	≤25
Resonant Impedance	
靜態電容	3300PF±10%
Static Capacitance	
最大功率(W)	65
Maximum Input Power	
前端外徑(mm)	φ40
Outside Diameter (Front End)	
壓電環外徑(mm)	φ38
Outside Diameter (Ceramic Ring)	
接觸面固定螺栓	M10*P1.0*10L
Fixing Bolt	
總高(mm)	55
Height	
重量(g)	283
Weight	
最高使用液溫(°C)	80
Max. Temp. of Liquid	
包裝(pcs/ctn)	30
Packing	
外觀	如右圖
Appearance	As shown on the right



80K
65W

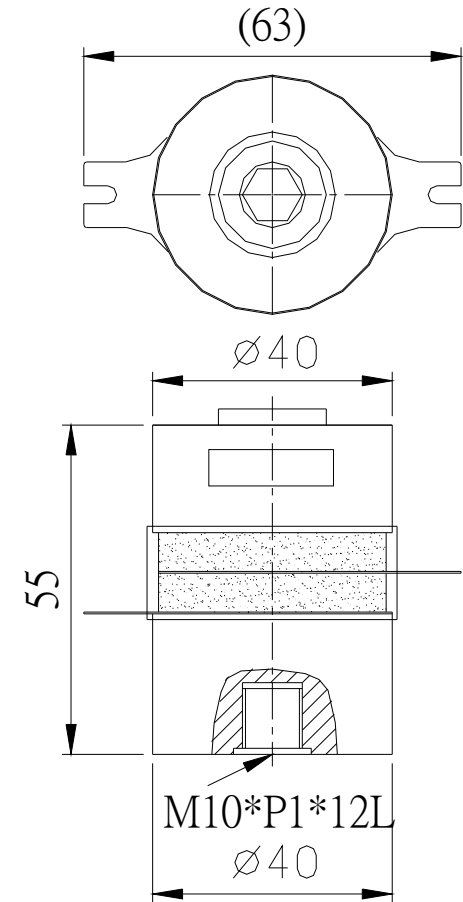

- 最佳的噴流清洗效果,高頻80K的動態細微噴流,半導體,面板業使用
Strong ultrasonic pressure wave; suitable for semiconductor industry and panel industry
- 可做三頻機使用40K/80K/133K切換
Can be used as three frequencies – 40K, 80K, and 133K

編號	WB12538-40HB
Model	(P8 黃片)
共振頻率(kHz)	125±2
Resonant Frequency	
共振阻抗(Ω)	≤25
Resonant Impedance	
靜態電容	3300PF±10%
Static Capacitance	
最大功率(W)	65
Maximum Input Power	
前端外徑(mm)	φ40
Outside Diameter (Front End)	
壓電環外徑(mm)	φ38
Outside Diameter (Ceramic Ring)	
接觸面固定螺栓	M10*P1.0*10L
Fixing Bolt	
總高(mm)	62
Height	
重量(g)	283
Weight	
最高使用液溫(°C)	80
Max. Temp. of Liquid	
包裝(pcs/ctn)	30
Packing	
外觀	如右圖
Appearance	As shown on the right



125K
65W

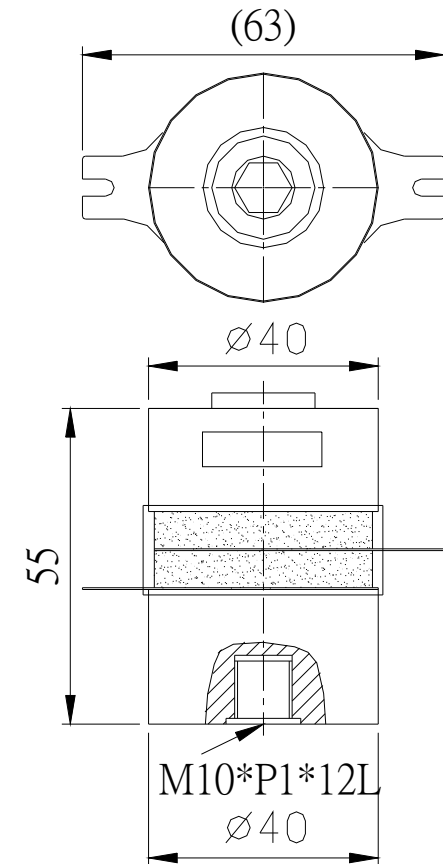

- 最佳的噴流清洗效果,動態工作時為高頻133K的細微噴流清洗效果,半導體,面板業使用
Strong ultrasonic pressure wave
While the 125K transducer is working, the frequency will become 133K. (suitable for semiconductor industry and panel industry)
- 可做三頻機使用40K/80K/133K切換
Can be used as three frequencies - 40K, 80K, and 133K

編號	WB16535-42HB
Model	(P4黑片)
共振頻率(kHz)	165±2
Resonant Frequency	
共振阻抗(Ω)	≤25
Resonant Impedance	
靜態電容	4000PF±10%
Static Capacitance	
最大功率(W)	45
Maximum Input Power	
前端外徑(mm)	φ42
Outside Diameter (Front End)	
壓電環外徑(mm)	φ35
Outside Diameter (Ceramic Ring)	
接觸面固定螺栓	M10*P1.0*10L
Fixing Bolt	
總高(mm)	62
Height	
重量(g)	277
Weight	
最高使用液溫(°C)	80
Max. Temp. of Liquid	
包裝(pcs/ctn)	30
Packing	
外觀	如右圖
Appearance	As shown on the right



165K
45W

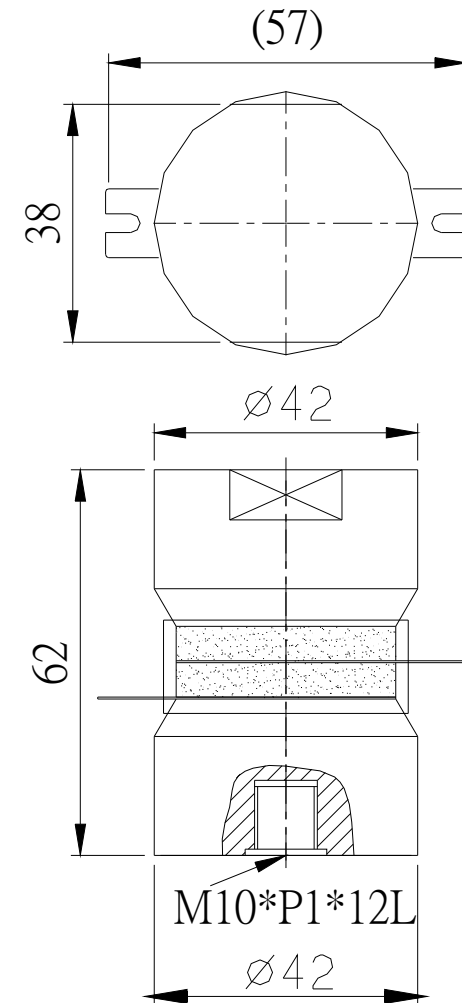

- 最佳的噴流清洗效果,動態工作時為高頻175K的細微噴流清洗效果,半導體,面板業使用
Strong ultrasonic pressure wave
While the 165K transducer is working, the frequency will become 175K. (suitable for semiconductor industry and panel industry)

編號	WB3525-25HB
Model	(P8黃片)
共振頻率(kHz)	35±2
Resonant Frequency	
共振阻抗(Ω)	≤50
Resonant Impedance	
靜態電容	1900PF±10%
Static Capacitance	
最大功率(W)	80
Maximum Input Power	
前端外徑(mm)	φ8
Outside Diameter (Front End)	
壓電環外徑(mm)	φ25
Outside Diameter (Ceramic Ring)	
固定方式	法蘭面鎖附
Fixed Method	Flange sealing
總高(mm)	151.5
Height	
重量(g)	200
Weight	
最高使用液溫(°C)	60
Max. Temp. of Liquid	
包裝(pcs/ctn)	30
Packing	
外觀	如右圖
Appearance	As shown on the right

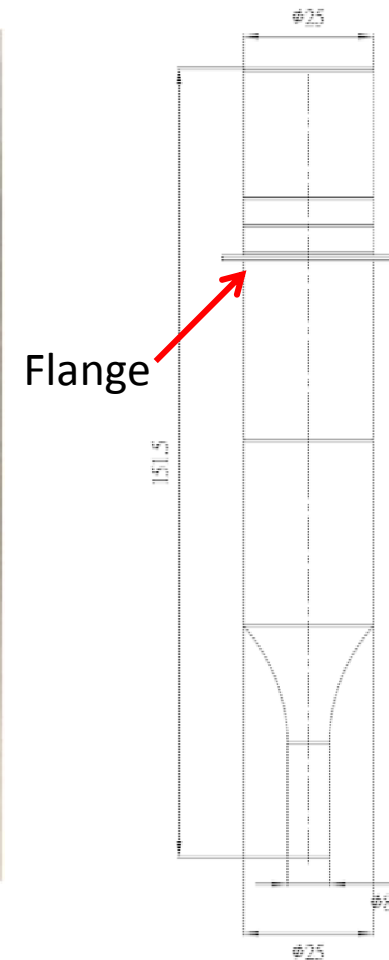

35K

80W

- 口罩機伸縮鬆緊帶焊接用
(連前端鈦合金焊頭一起出貨)
Suitable for welding (ex. face mask earloop welding)
Purchased with the front-end titanium horn